

1. Mr. and Mrs. Burke's yard measures 40 ft. by 30 ft. Their garden in this yard measures 30 ft by 4 ft. By how many **square feet will the grass area decrease** if the Burke's increase the garden's width by 5 feet?

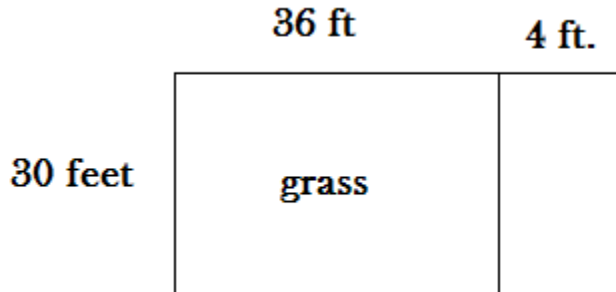

2. An interior designer wants to order wallpaper border to place at the top of the walls in the rectangular room shown. If one roll of border is 5 yards long, how many rolls of border should the designer order?

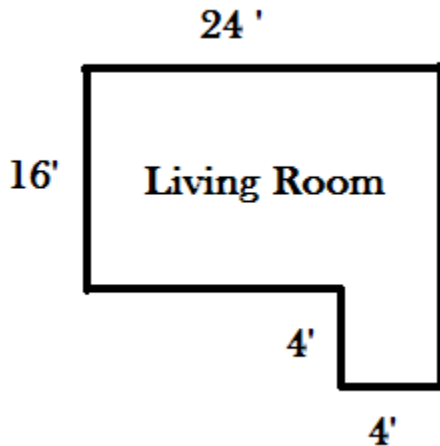

3. The Burke's are having their wooden deck stained. The company doing the work charges \$3.50 per square foot for staining. Each square on the grid represents **1 square yard**. Estimate the area of the deck to the **nearest square foot** and calculate the cost to stain the deck.

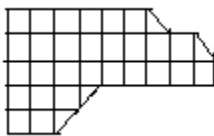

4. Consider this scale drawing of the lake. Using the given scale, estimate the perimeter to the nearest 10 yards and the area to the nearest 100 square yards.

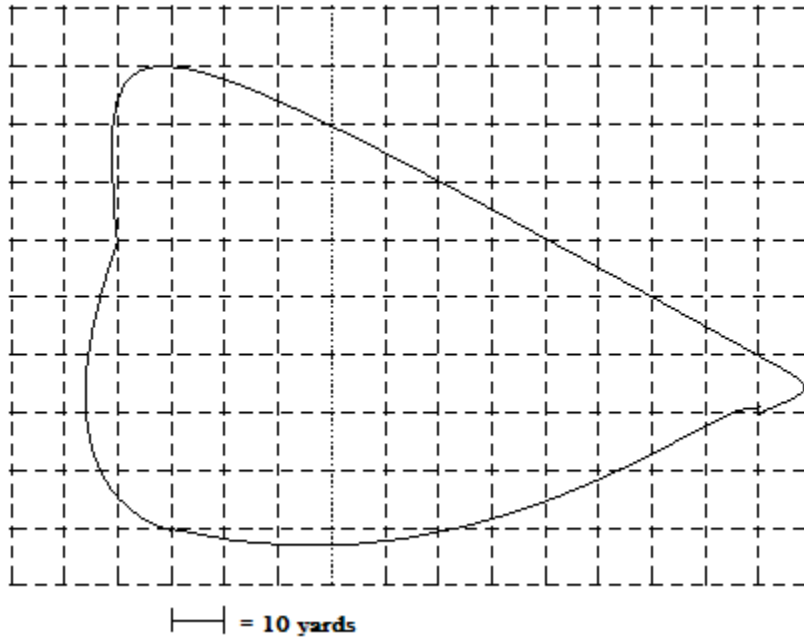

5. To determine how much of each item to buy, tell whether you need to know area or perimeter.
- a) wallpaper for a bedroom
 - b) weather stripping for a door
 - c) fence for a garden
 - d) paint for a basement floor
6. What is the maximum home square footage you can build for \$132,000 if the building cost is \$78 per square foot?

7. Solve for x

a) $2x + 1 = 11$

b) $-5 - 3x = -15$

c) $8 = 3x + 7$

d) $-32 = 7x + 3$

e) $9 - 5x = 54$

f) $7x - 6 = -48$

8. The plans for a new Estes Park high-rise office tower show that the shape of the building will be a regular hexagon with each side measuring 350 feet. Find the area of a floor if the apothem is 303 ft long.

9. Mrs. Gatti is preparing to paint her house. If a gallon of paint covers 450 sq. ft, how many gallons of paint does she need to cover the side of the house shown below.

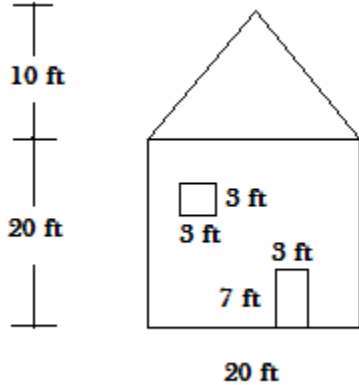

10. A stop sign is a regular octagon whose sides are each 10 in. long and whose apothem is 12 inches long. Find the area of a stop sign.



11. Jonathan wants to wallpaper the four walls of his room. The room is rectangular and measures 11 ft by 13 ft. The ceiling is 10 ft high. A roll of the wallpaper Jonathan has chosen is 2.5 ft wide and 50 ft long. How many rolls should he buy?

12. Find the approximate area of Fort Jefferson, which approximates a regular pentagon, in Dry Tortugas National Park, Florida if each side is 460 feet long and an apothem is about 398 feet long.



13. A civil engineer is able to determine that 50,000 cubic yards of gravel is in the shaded portion of the tract of land shown. How many cubic yards of gravel would you estimate the engineer could excavate for the whole tract of land?

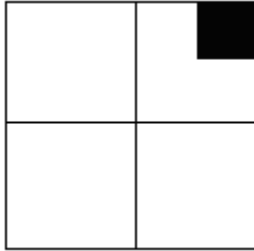

14. Aunt Melissa is ready to have carpeting installed. The carpeting she has selected costs \$18 per square yard, the padding \$4 per square yard, and the installation \$4 per square yard. What will it cost her to carpet the bedroom and the hallway shown?

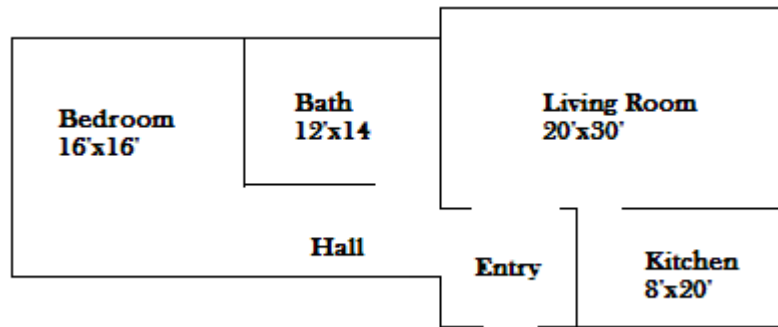

15. Ethan divides a rectangle into three sections, as shown below. Write an algebraic expression to represent the area of section I?

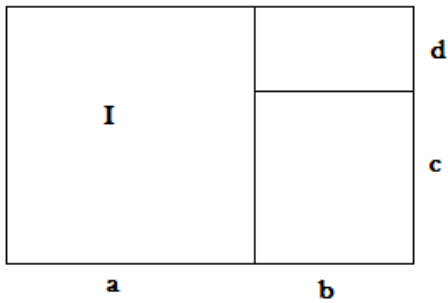

16. The grassy outfield of Mountain View High School’s rectangular baseball field, shown in the diagram below, is going to be reseeded with new grass. The infield, which is in the shape of a quarter circle, will not be covered with the new grass. How many square feet of the baseball field will be reseeded with new grass? Explain your answer by showing the sub problems.

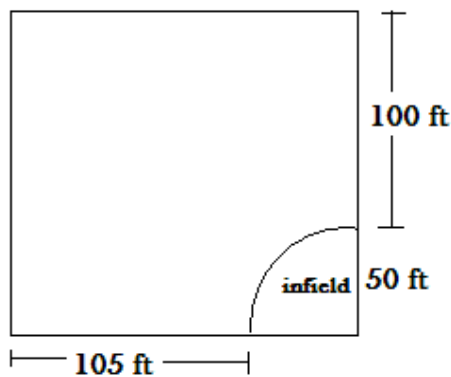

17. The diagram below shows a rectangular hip roof. It consists of two trapezoids and two isosceles triangles. The area of the roof determines how many bundles of shingles a roofer needs to cover the roof. (Three bundles cover approximately 100 square feet, an area called a *square*.) Find the area of the roof below.

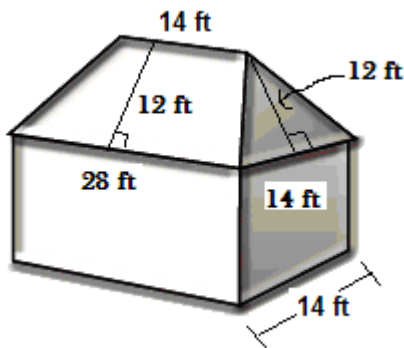

18. Find the front surface area of the chimney of the fireplace below.

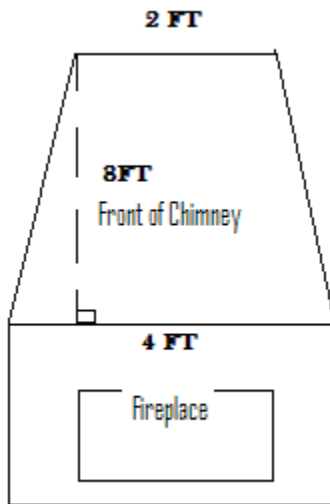

19. Find the requested value

a) Find the area of the parallelogram shaped window

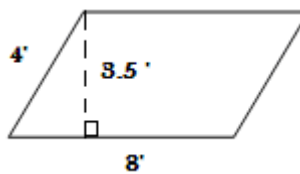

b) The figure is a rectangular wall with perimeter 111 yards. Area = _____

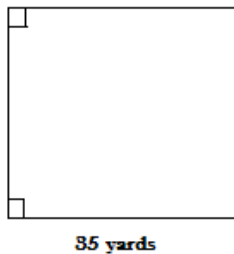

c) The area of the parallelogram shape lot is 88200 sq ft. $h =$ _____

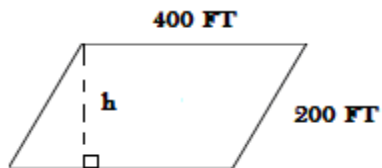

d) Area of the play area at the playground = _____

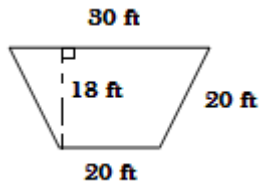

e) The perimeter is 148 in and the area is 920 in^2 . $h =$ _____

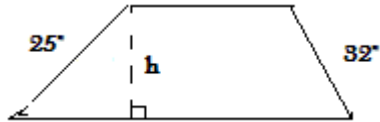

f) The corner area of a utility region of a subdivision has a shape of an obtuse triangle which has area of 135 sq ft. $h =$ _____

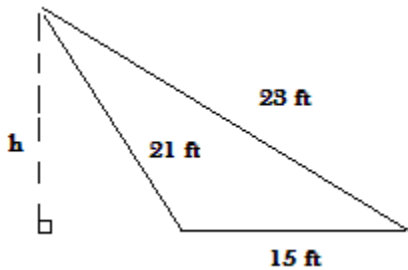

g) The area of the trapezoid window is 250 sq in. $d =$ _____

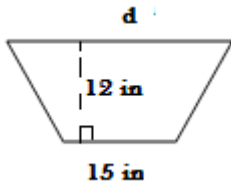

h) Each side of the regular pentagonal window is 11.8 in and the apothem is about 8.4 in. Area \approx _____

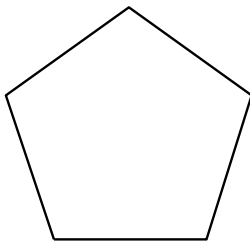

- i) The shaded portion of the regular octagon represents a redwood deck that is to be stained. The apothem is about 14.5 ft.

Shaded area _____

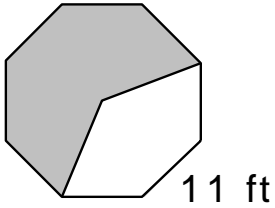

- j) The circumference is 22π yd. Find the area of the circular deck. Area \approx _____

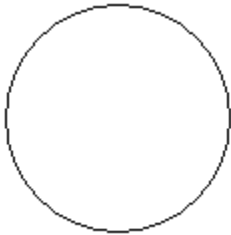

20. Solve for n

a) $3n - 6 = 7n + 6$

b) $\frac{2}{3}x + 5 = 11$

c) $\frac{x}{2} - 7 = 18$

d) $-4n - 6 = n + 8$

e) $6n - 10 = 38 - 10n$

f) $-84 - 6n = 15n$

21. For each pair of figures complete the table.

A

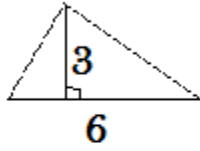

B

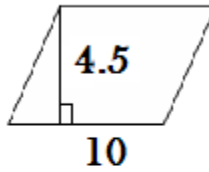

C

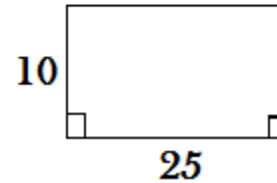
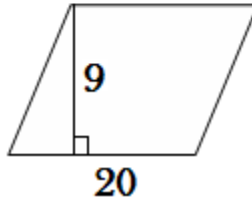
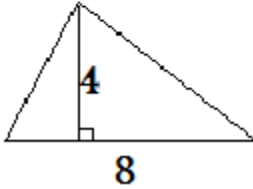
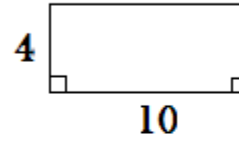

	A	B	C
calculate area of each			
ratio of area sm to large			
ratio of sides sm to large			

a) Any patterns between the area ratios and the side ratios?

22. Mindy drew a figure by drawing squares and parts of circles as shown below. What is the area of Mindy's figure in square inches? Explain by showing the sub problems.

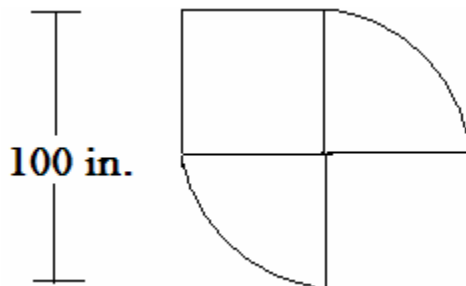

23. The students in the Art Club are tiling a wall at the entrance to room 111 that is 8 ft by 16 ft. They are using tiles that are 6 in. by 6 in. to create a multi-colored design. How many tiles do the students need?

24. The LHS construction class has several designs for decks. Find the area of the deck below.

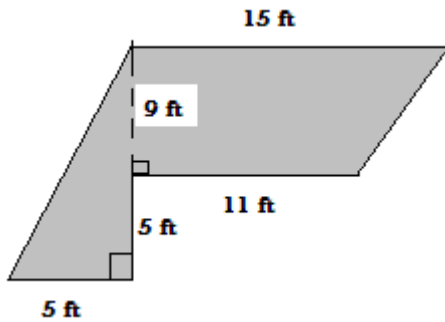

25. Before Aaron can be a real estate agent, he must obtain a license. All states require prospective agents to pass a written test which usually contains a section on real estate mathematics such as:

Determine the total square footage of the kitchen and dinette in the blueprint.

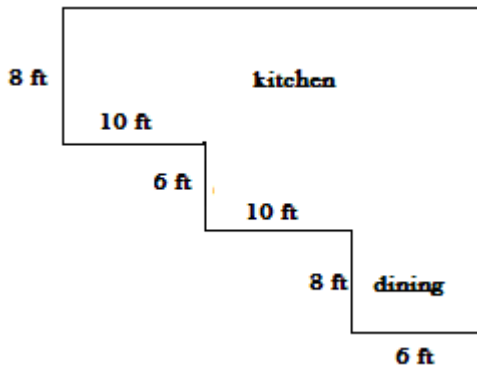

26. Aunt Melissa wishes to lay 1-foot-square Italian Buff ceramic tile in her entryway and kitchen. Italian Buff cost \$6 each. She wishes to lay 3-inch-square ceramic tile on the bathroom floor. The bathroom tile she has selected costs .95 per tile. What will it cost Aunt Melissa to tile her home?

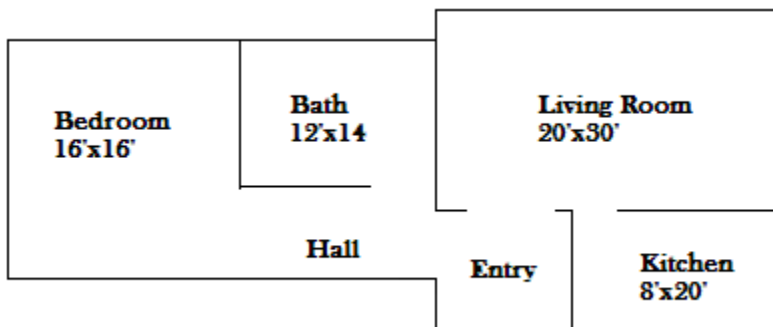

27. Using the rectangle below, write an algebraic expression for the

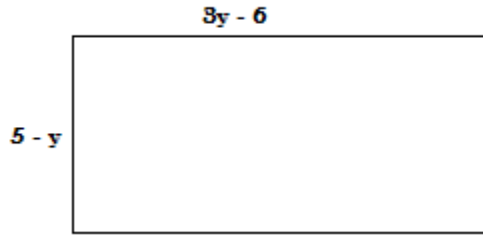

a) perimeter

b) area

28. Simplify

a) $4x + 2x$

b) $5x - x$

c) $5x \bullet x$

29. Truth Realty Co. is selling riverfront lots along a straight stretch of the Big Thompson River. They are priced at \$300 per front foot (measured along the riverbank). They advertise the land at “only \$1 per square foot.” As you can see, the boundary line does not go back from the shore at right angles.

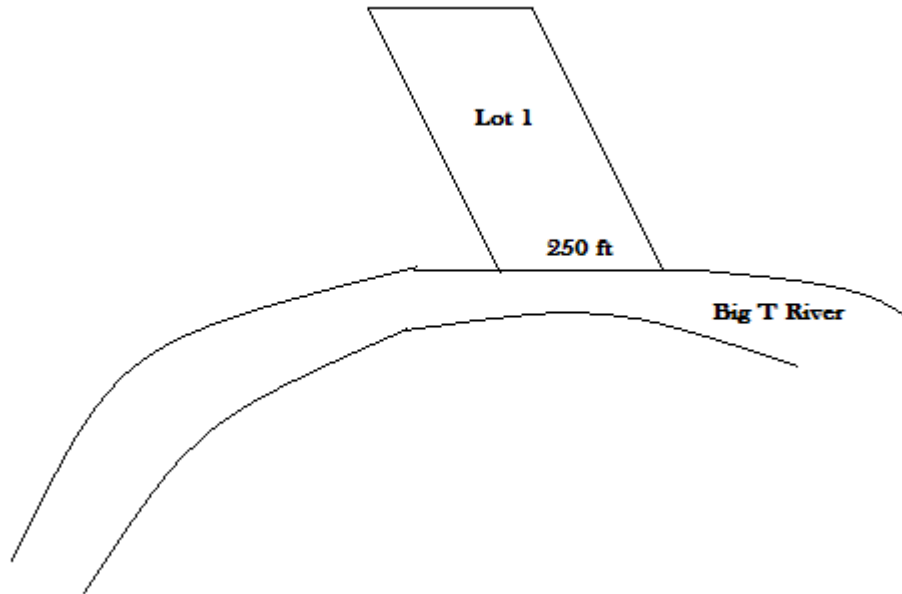

- By measuring using a ruler, find the scale of Lot 1. Use the riverfront as the base.
- What is the height of lot 1? What is the area of Lot 1?
- What is the price based on \$300 per front foot? What is the price based on “only \$1 per square foot”?

30. The Castel del Monte in Apulia, Italy, was built in the 13th century. The outer shape and the inner courtyard are both regular octagons. The outer shape has each side about 50 ft. long with the apothem of 30 ft.



- a) Find the total area of the castle, including the courtyard.
- b) Find the area of the courtyard if the octagonal courtyard has an apothem of 14.5 feet and sides of 12 feet.
- c) What is the area of the inside of the castle, not including the courtyard?

31. Find the area of each roof. How many squares of shingles will need to be purchased?

- a) The rectangular top portion of this roof will not be shingled. Only the sloping portions will be shingled.

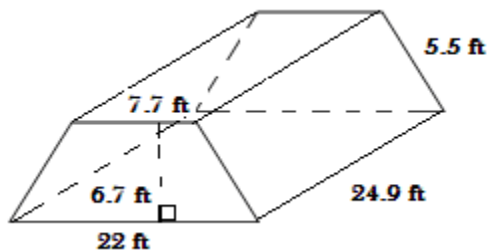

- b) This roof consists of four sloping rectangular surfaces.

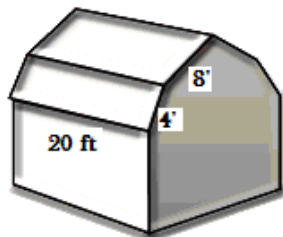

Gambrel Roof:

32. The customer wants you to estimate the cost of shingling the roof for a new home. Calculate the area, the number of squares of shingles, and the cost (a square of shingles cost \$65). VIEW FROM ABOVE. Shingles are purchased by a unit called a square. One square of shingles = 100 square feet.

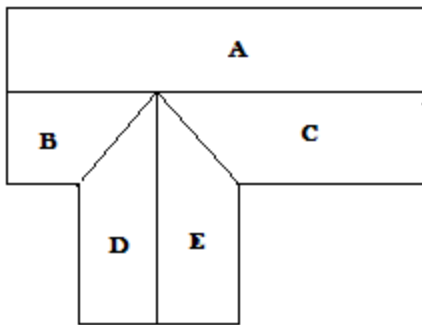

Roof section details are shown below which are rectangles and trapezoids.

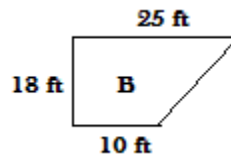
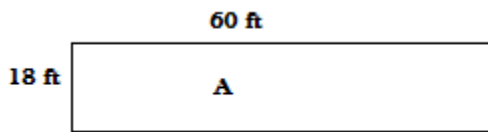

Sections D and E are identical

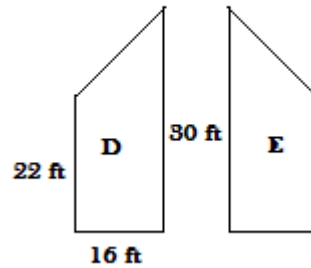
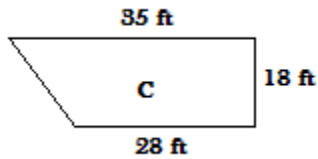

33. Find the area of the rectangular floor structures shown below:

a)

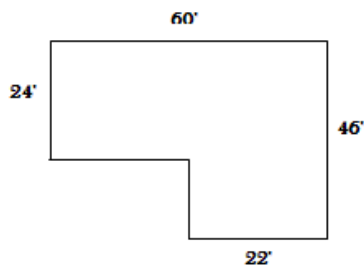

b)

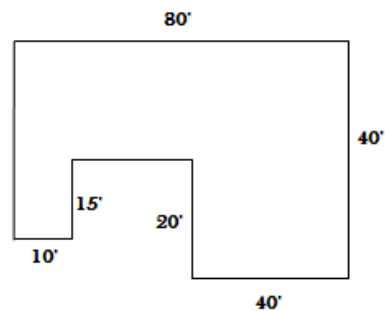

34. Estimate the number of 4 by 8 foot sheets of OSB needed to cover the exterior of this cabin. A sketch of one end and one side is shown below. Remember the cabin has 4 sides.

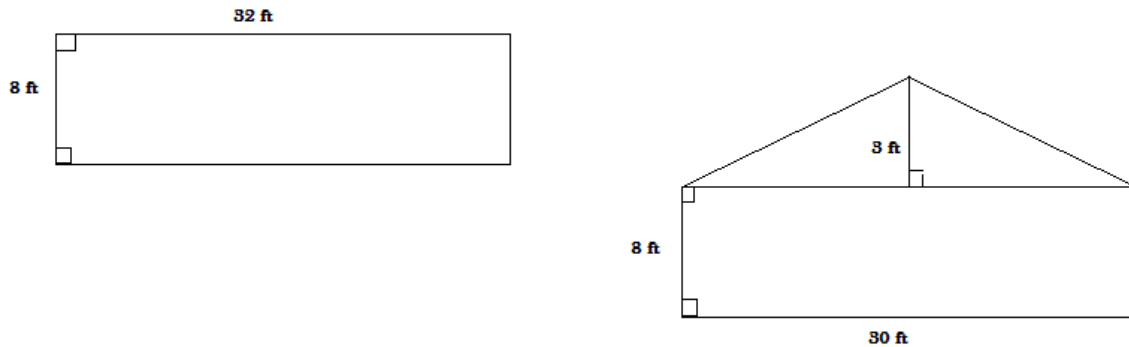

35. Convert 8' 10" to feet...ready to enter into your calculator.
36. The cabin is to have carpet in 2 bedrooms. Bedroom one is 8' 10" by 11' 4" and bedroom two is 11' 0" by 14' 4". How many **Square Yards** of carpet are needed?
37. Find the number of 4 x 8 foot sheets of plywood needed to cover the floor of the cabin if the cabin measures 30' by 32'.

38. Find the area of the deck surrounding the hot tub. The hot tub has a diameter of 10 ft.

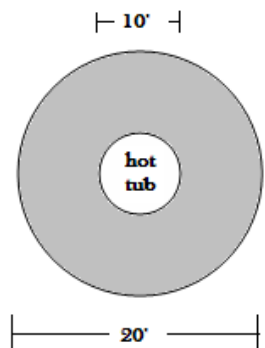

39. Solve for the indicated variable.

a) $\frac{2}{5}x - 8 = 19$

b) $-4x - 9 = -2x + 5$

c) $3(2x - 7) = 45$

d) $\frac{x}{2} - 5 = 34$

e) $5 - x = 6x + 5$

f) $17 = -(2x + 7)$

40. The Great American Pyramid in Memphis, Tennessee, is a regular pyramid with a square base. Each side of the base is about 544 feet long. The slant height is about 420 feet. Find the area of the outside **walls** of this structure. Find the **floor** area.



41. Find the amount of glass needed to build the greenhouse. The entire greenhouse is covered in glass. Ignore the framing.

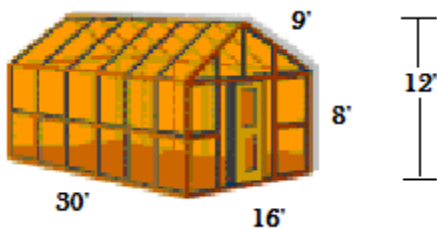

42. Buford is an apprentice painter. His boss, Mini Pearl, is ill. It is up to Buford to make an estimate on painting 149 rooms in a new motel with one coat of primer and one coat of finishing paint. The four walls and the ceiling of each room must be painted. Each room measures 11' X 15' X 9' high.

a) Calculate the total area of all the surfaces to be painted with one coat. Ignore doors and windows.

b) One gallon of primer covers 500 sq ft. How many gallons of base paint are required for the job?

c) One gallon of finish paint covers 200 sq ft. How many gallons of finish paint will it take to complete the job?

43. Find, to the nearest hundredth, the amount of insulation needed to cover the sides of the 40 gallon hot water heater. The insulation only covers the sides of the hot water heater. Find the lateral area (SIDE ONLY).

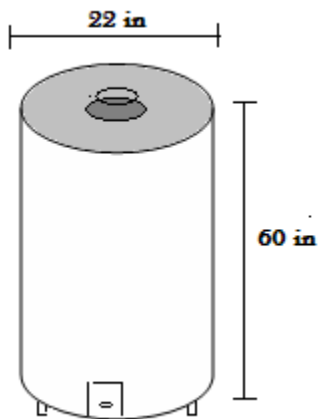

44. The Loveland town council wants to build a bandstand. Architects were asked to submit plans. In the plan shown, the floor has the shape of a regular octagon.

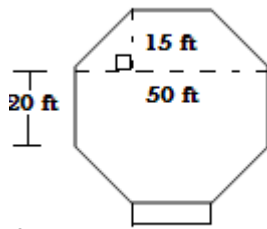

a) What is the area of the floor of the bandstand in this plan?

b) What would the dimensions be of a square bandstand with the same area as the octagon above?

c) Which one has the largest perimeter?

45. Find the area of the shaded regions.

a)

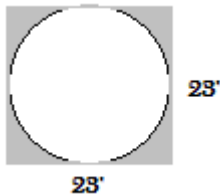

b)

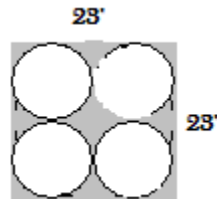

c)

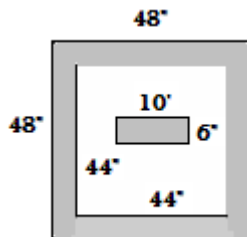

d)

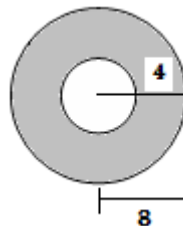

46. Find the surface area.

a) square base pyramid

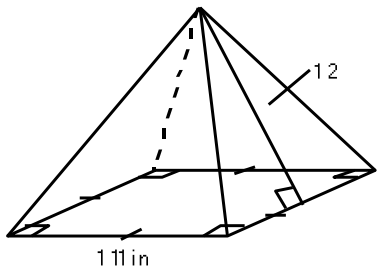

b)

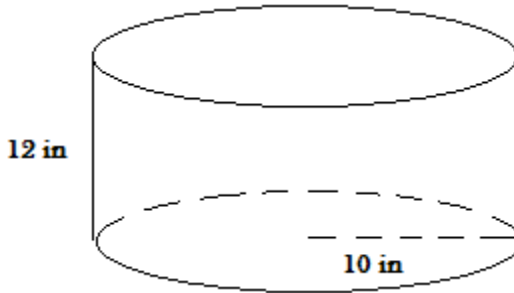

c)

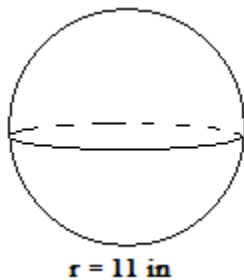

d)

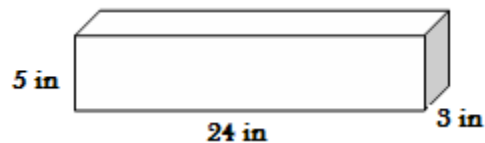

e) Find the total surface area of the trapezoidal prism. Measurements are in feet.
Surface area \approx _____

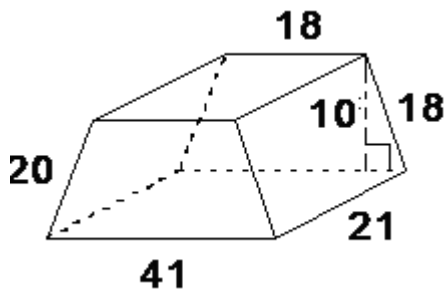

f) Find the lateral surface (ignore floor and ceiling) area of a 14' X 70' mobile home with 10' high walls.

47. Find the circumference of a circular window if the area is 100π sq units.
48. Find the circumference of a circular pier if the area is 24π sq units.
49. Find the circumference of a circular drainage pipe if the area is 153.86 sq units.
50. Find the circumference of a circular window if the area is 254.34 sq units.
51. Calculate the cost of the window below using the table. Each pane is priced separately. The panes are square or circular.

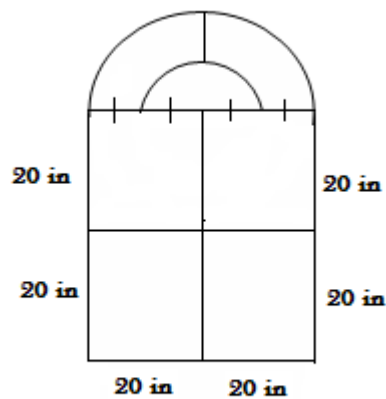

Area	Price
0-100 sq in	\$25
100-150 sq in	\$45
150- 250 sq in	\$80
251-500 sq in	\$140
501-1000 sq in	\$225
over 1000 sq in	.20 per sq in

52. Below are some regular polygonal windows each with an area of 250 sq in. Find the length of each side given the apothem.

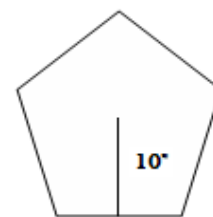
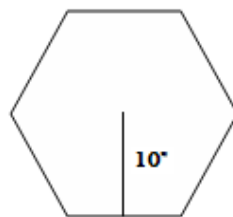
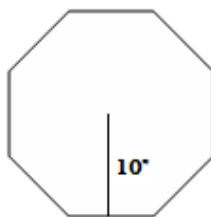

53. Solve for x

a) $3x = 3x + 5$

b) $4x + 12 = 2(2x + 6)$

c) $3x + 5 = 5$

54. Substitute any number you choose into 53b, what do you notice? How is this different than 53a?

55. Find the area of the circle clock tower face if the circumference is 24π units.

56. Find the area of the circular water pipe cross section if the circumference is 50π units.

57. Find the area of the circular cutout for a circle staircase if the circumference is 50.24 units.

58. Find the area of the circular cutout for a vent pipe if the circumference is 47.1 units.

59. Aaron ties his dog, Tamar, to the side of the house with a 15 foot leash. The distance from A to B is 20 ft.

a) If he ties Tamar at point A, how much area does the dog have in which to wonder?

b) If he ties Tamar at point B, how much area does the dog have in which to wonder?

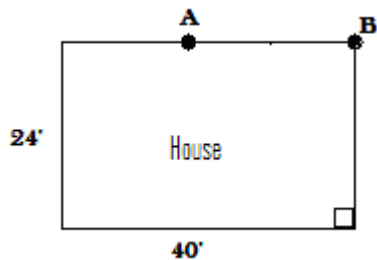

60. Window cost can be estimated by the size of the glass panes. Use the drawing below to calculate the window cost if the glass is \$7.60 per square foot.

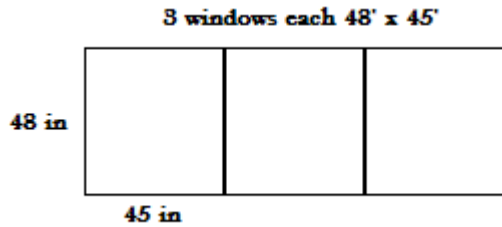

61. In North Carolina, a subdivision of round homes have been built at the base of one of the ski resorts (small resort but...big by North Carolina standards). Below are some of the footprints of the homes. Note that the shaded part is not part of the home but rather a deck/viewing area. Find the area of the livable space in each of the homes shown below. The radius is 24 feet.

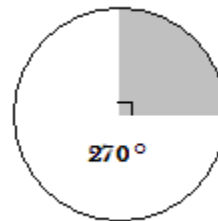
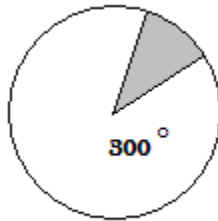
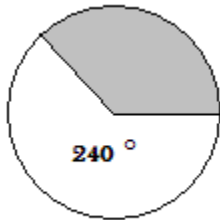

62. Find the surface area of the various homes. **Ignore the floor.**

a) Igloo with 20 ft. diameter



b) Miwok Tribe with 20 ft diameter cylinder with an 8' tall walls with a hemisphere roof



- c) Long house with 50' length and radius of 5' end section of a 10' square



- d) US military quonset hut
half cylinder roof of 8' radius



- e) Tepee with 6 sided regular hexagon base each hexagon side 10' with a slant height of 12'



- f) A 15' length lean-to with one end triangle with a 10' base and a perpendicular height of 10'

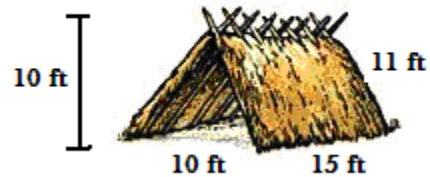

63. Christina bought the lot shown below. What is the area of the lot? If the county requires the back 30% be left for open space, what is the maximum square footage of the building?

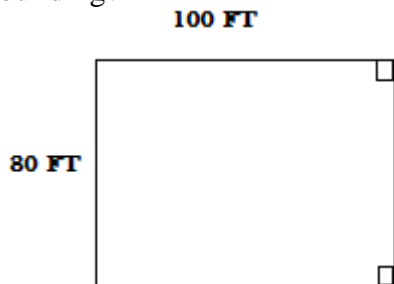

64. You are subdividing the lot below. The county requires each lot be at least 8000 sq. feet. Decide how many lots? What are some of the concerns you would need to address to get the maximum number of lots?

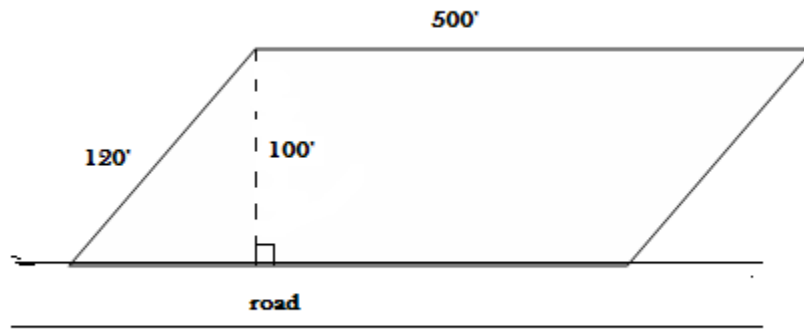

65. On the blueprint of a house, the kitchen is 5 inches long. If the actual kitchen is 20 feet long, find the scale of the blueprint.

66. An architect planning a new home wants to design a square living room with about 600 sq. feet of floor space. What dimensions should the architect show on the blueprint?

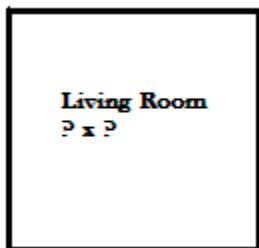

67. Solve for x

a) $5x - 7x = 3(5 - x)$

b) $4(x - 2) = 3x - 8 + x$

c) $-4 - 5x = 9x + 10$

d) $2x - 6 = 2x$

68. Mrs. Larson's math class is using cardboard to build a scale model of the Great Pyramid of Khufu in Egypt. The surface area of this pyramid is about 1,496,510 sq. feet. If the scale factor of the surface area of the model to the original is 1:100, how much cardboard will the class need to make the model?

69. The area of a square is 9 sq. units. If each side of the square is doubled, what is the area, in square units, of the new square?

70. The dimensions of Liz's rectangular garden are shown below.

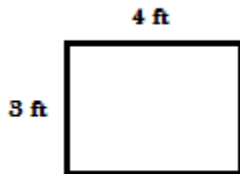

a) If the length of the garden is tripled, describe what happens to the area?

b) If the length and width of the garden is tripled, describe what happens to the area?

71. Rene's rectangular house measures 35 feet by 98 feet. Rene's bedroom is similar in shape to Rene's house. The ratio of the dimensions of Rene's bedroom to the dimensions of her house is 1:7. What are the dimensions of Rene's bedroom?

72. If the scale is 1 foot = $\frac{1}{4}$ inch, how big will a room 10 feet by 12.5 feet be on the scale drawing?

73. The rectangular floor of Logan's living room is 12 feet by 18 feet. A rectangular wood inlay is placed in the middle of the room. What is the area of the rectangular inlay?

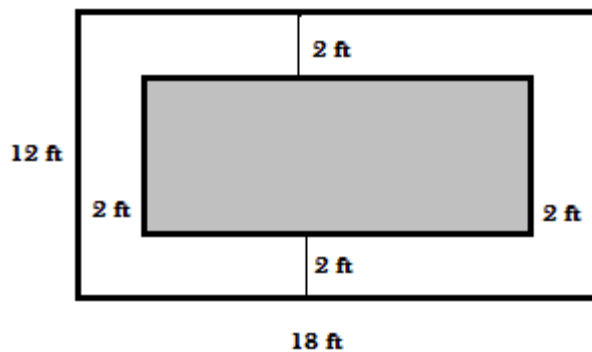

74. Find the perimeter of the parallelogram lot if the area is 8800 sq. feet.

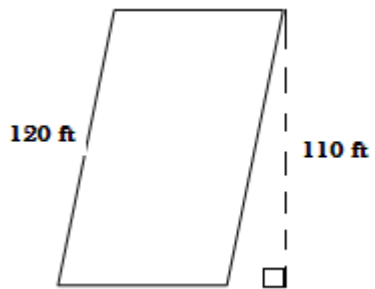

75. Find the area of the regular pentagonal window.

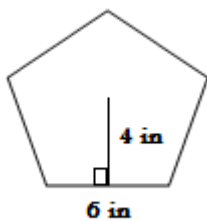

76. Find the surface area of these houses. Assume side wall height of 8 feet. Ignore floors and include roof.

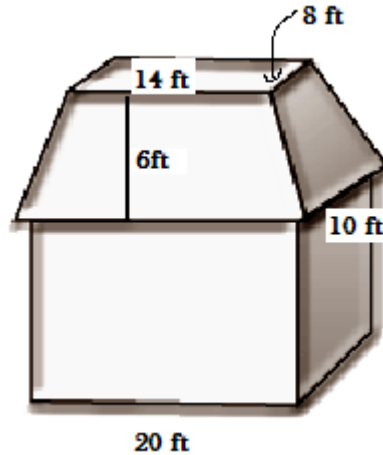
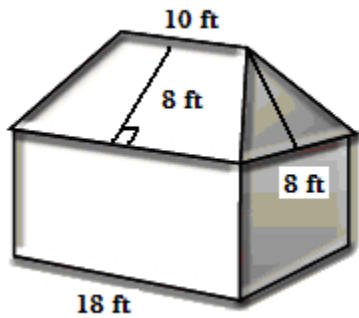

77. Find the apothem of the regular hexagon entry way with the area of 200 sq feet.

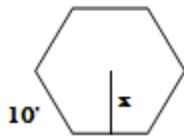

78. Solve for x.

a) $1 - 2(2x + 1) = 11 + 2x$

b) $6 - 2(3x + 5) = 8$

c) $5x - 8x = 3(5 - x)$

d) $4(x - 2) = 3x - 8 + x$

79. Model train scales are given as $\frac{\text{Length of model}}{\text{Length of train}}$. An N-gauge model train has a scale of 1:160. An HO-gauge model train has a scale of 1:87.

- a) If an N-gauge caboose is 4 inches long, what is the length of the actual caboose?
- b) Using the measurement of the actual caboose in part a, find the HO scale model length of the caboose.

80. A reporter used the graphic below to show that the number of houses with more than two computers had doubled in the past 3 years. Explain why this graphic is misleading.

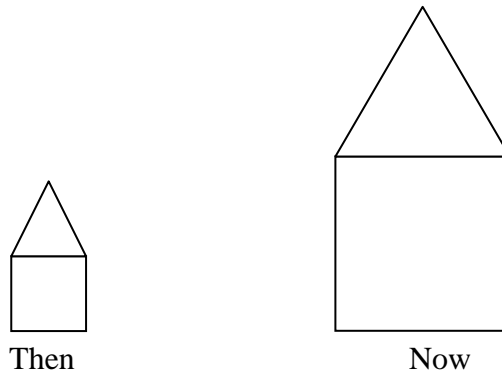

81. What is the actual length of Store 4 in the Loveland Court mall to the nearest foot? Assume the stores are rectangular.

1/8 in = 10 ft

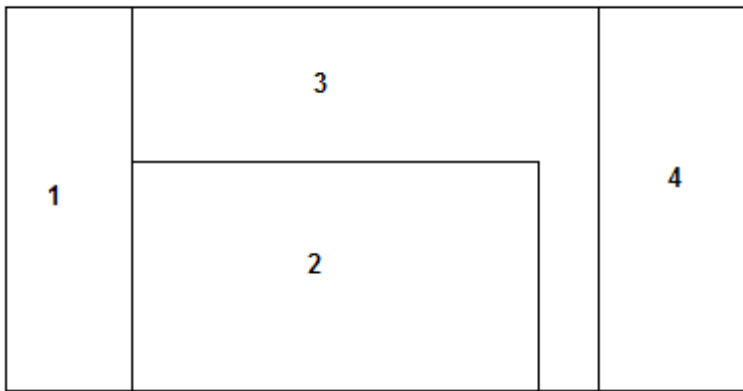

82. In the blueprint, $\frac{1}{2}$ inch represents an actual length of 8 feet. Find the actual dimensions of the rectangular living room.

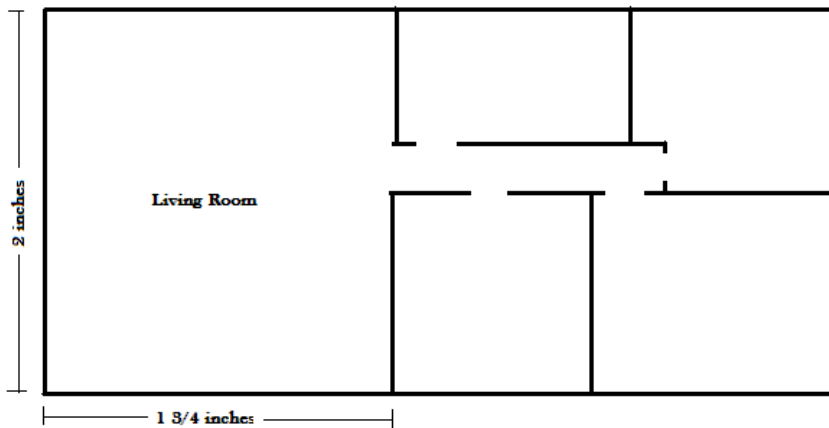

83. Find the missing length given the triangles in the truss support are similar.

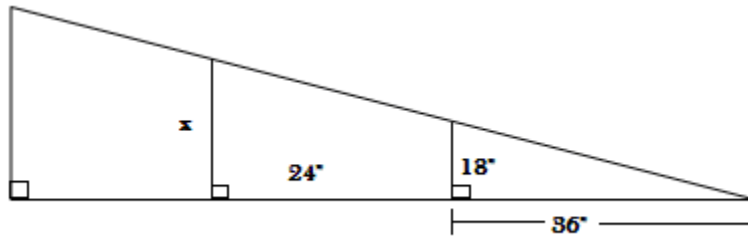

84. Cassandra wants to determine the distance across the street in front of her house. A drawing is shown below.

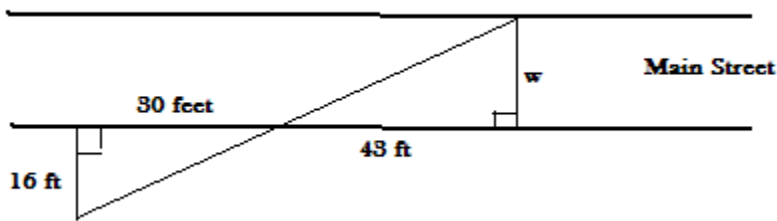

What is the width (w) of the street in feet? Explain how you got your answer.

85. Are the gables on your home (or pick any house) similar, congruent, or neither. Why?

86. In sunlight, a pole casts a 9 ft. shadow. At the same time a person 6 ft. tall casts a 4 ft. shadow. Use similar triangles to find the height of the pole.

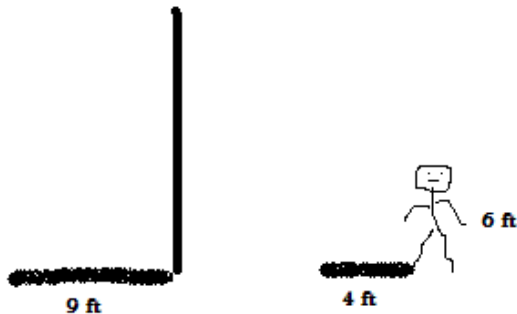

87. When building a roof, a 4 foot support is to be placed as shown on the diagram. Find the length of the support x that is to be placed.

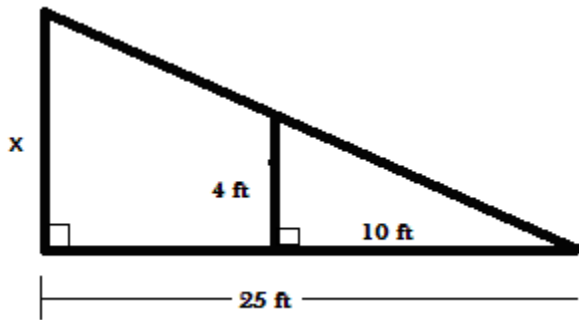

88. Given the scale is $\frac{3}{4}'' = 1'$, find the scale size of a room that measures 10' by 12'

89. Convert 8.4 ft to inches.

90. The figure below shows geoboard rectangles nested inside each other. Explain why the two rectangles on the left are similar but the two rectangles on the right are not.

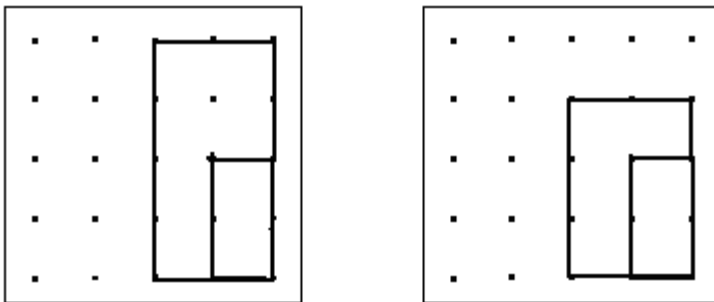

91. Solve or simplify

a) $5x \cdot 2x$

b) $5x + 2x$

c) $\frac{3x}{4} = \frac{2}{3}$

d) $\frac{3}{4} \cdot \frac{2}{3}$

92. Connor is drawing a scale model of a car he is designing. If $\frac{1}{4}$ inch on the drawing represents 12 inches, find each measurement on the actual car (length, height).

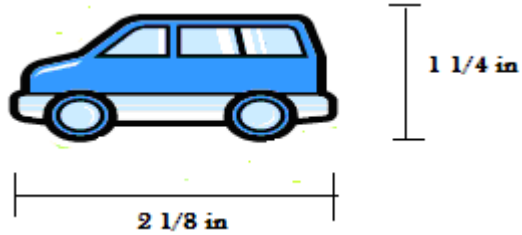

93. The flagpole on the left casts a shadow 30 feet long. The flagpole on the left has a height of 20 feet and casts a 18 foot shadow. How tall is the flagpole on the right? Round your answer to the nearest foot.

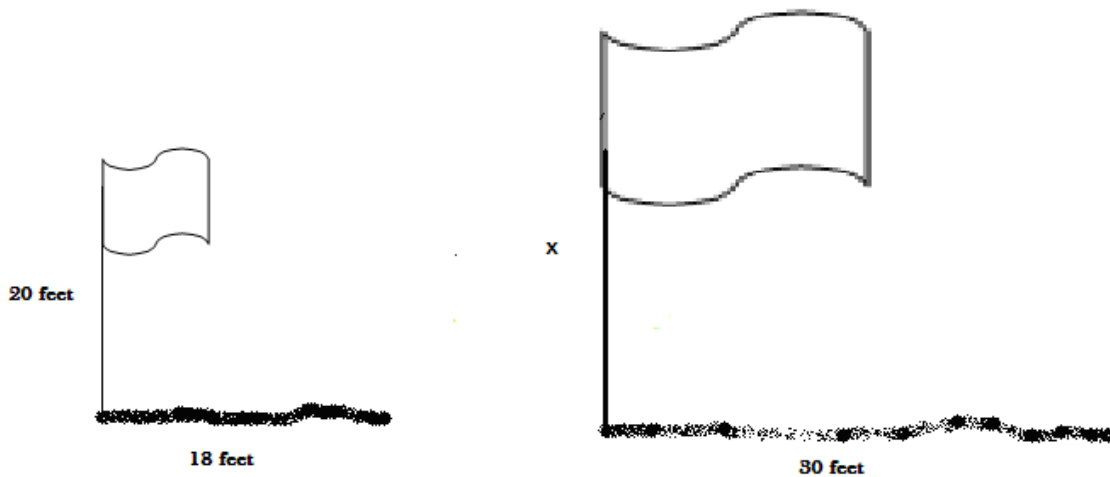

94. A bird's-eye view of the Pentagon reveals five similar pentagons. Each side of the outside pentagon is about 920 feet. Each side of the innermost pentagon is about 360 feet.

- Find the scale factor of the outside pentagon to the innermost pentagon.
- Find the perimeter of the outside pentagon. Innermost pentagon.
- Find the ratio of the perimeter of the outside pentagon to the perimeter of the innermost pentagon
- Tell how the ratio in part a compares to the ratio in part c. Reduce the ratio in part c if necessary.



95. Sam places a mirror on the ground 33 ft from the base of a building. He walks backwards until he can see the top of the building in the middle of the mirror. At that point, Sam's eyes are 6 ft above the ground and he is 10 ft. from the image in the mirror. Use similar triangles to find the height of the building.

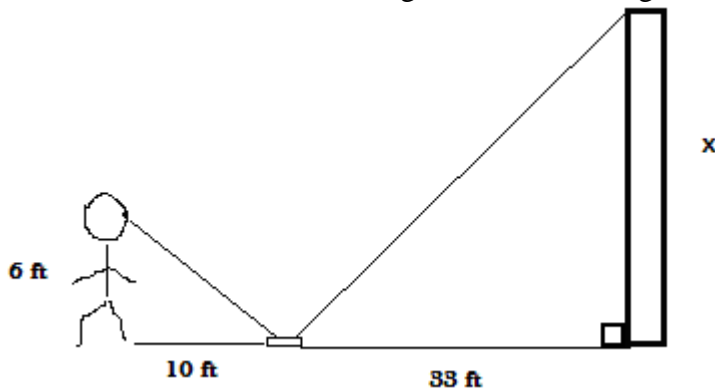

96. A roof rafter is shown. Find the length of the brace.

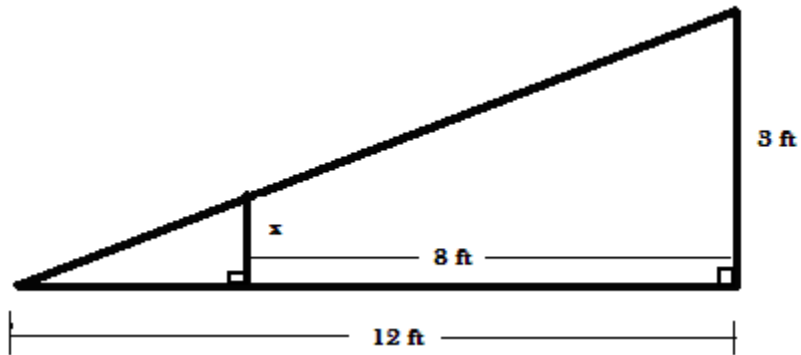

97. Alyssa wants to find the distance across Loveland Lake. According to her measurements, what is the distance across the lake?

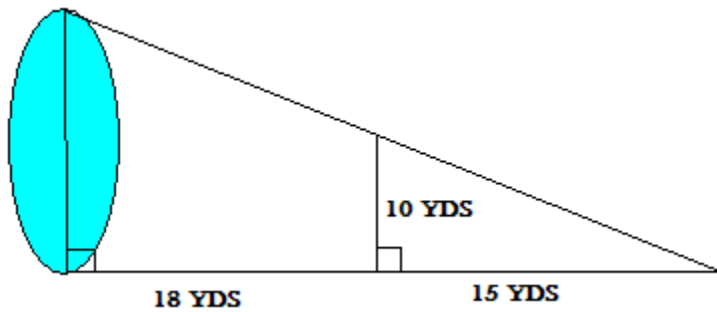

98. Eric is building a sawhorse. According to the diagram, how long should he make the brace?

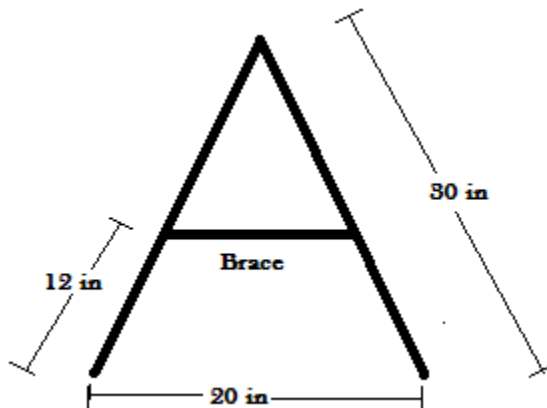

99. Jeremy is cutting a tree down and he needs to know the tree's height. The tree's shadow is 21 feet long at the same time that Jeremy's shadow is 4 feet long. If Jeremy is 6' 3" tall, how tall is the tree?

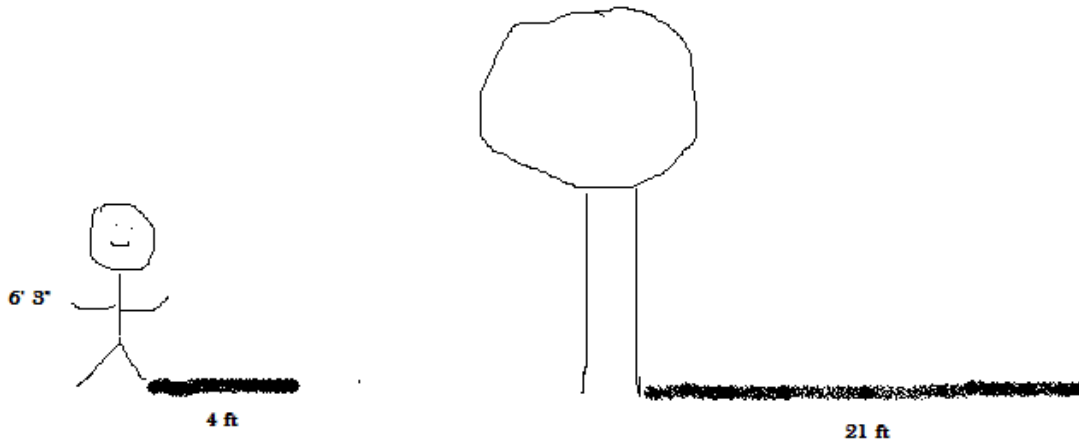

100. Darla drew the figure below. \overline{BC} is half the length of \overline{AB} . What is the length of \overline{BE} ?

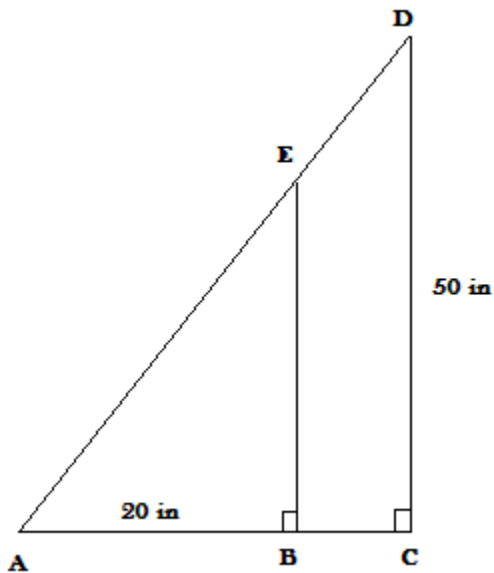

101. On a piece of graph paper,
- Draw a 2 unit by 3 unit rectangle
 - Draw 2 different rectangles, each similar to the original rectangle and label them I and II

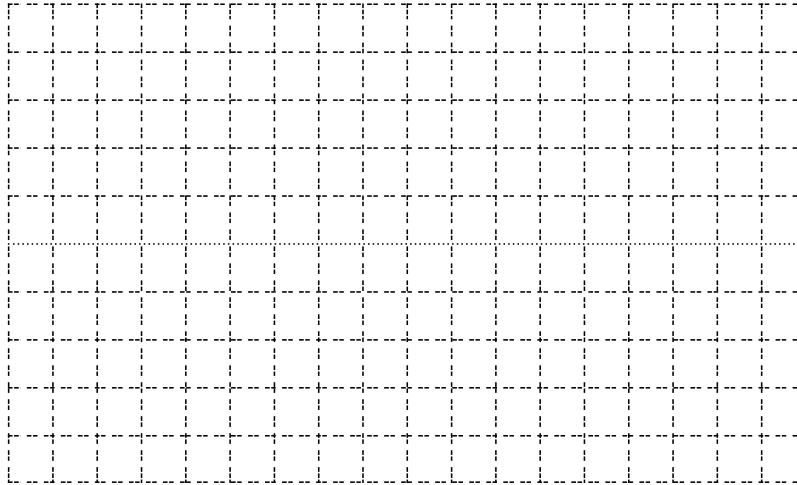

- c) Complete the chart below

Rectangle	Perimeter	Area
Original		
I		
II		

- d) Use the information from the first chart to complete the chart below

	Similarity Ratio	Perimeter Ratio	Area Ratio
Original to Rect. I			
Original to Rect. II			

- e) How do the ratios of perimeters and the ratios of areas compare with the similarity ratios?

102. Which is a better buy? Laminate wood flooring costs \$70 for a 4 foot by 5 foot area or \$93 for carpet for an 11 foot by 3 foot area? The cabin living room is 15' 10" by 14' 4". What would it cost to carpet it? Laminate floor costs?

103. Aaron works at the Reporter Herald. A client has just requested that his 2 inch by 5 inch ad be increased in size by doubling each dimension. If the original ad cost \$450, what will the costs of the new ad be?

104. Solve for x

a) $\frac{x+1}{12} = \frac{3}{5}$

b) $\frac{x+1}{2x+3} = \frac{3}{5}$

c) $\frac{5x}{3} = 10$

105. A model of a car, complete with wheels, is $\frac{1}{15}$ the size of the actual car. The radius of each wheel on the model is 3 centimeters. What is the circumference, in centimeters, on each wheel on the actual car? Show your sub problems to explain your thinking.

106. Find the surface area of the four buildings. Do not include the floor.

a)

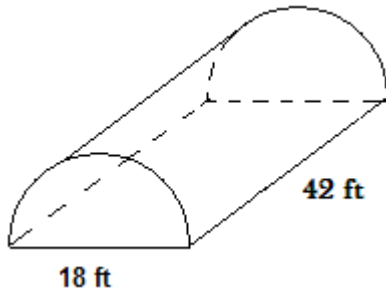

b)

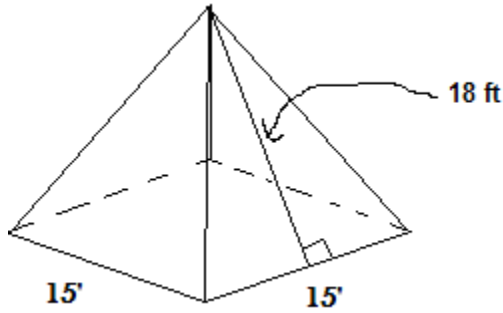

c)

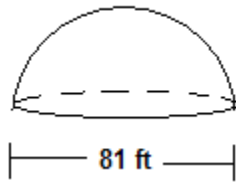

d)

Regular hexagonal prism Apothem = 6.9 ft

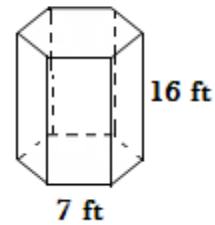

107. Find the missing values for the blueprints shown.

a)

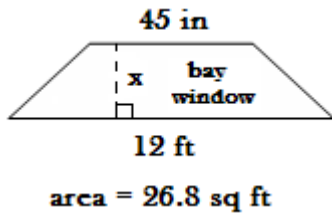

b)

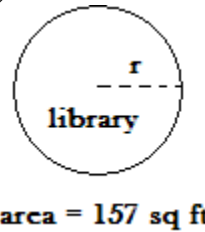

c)

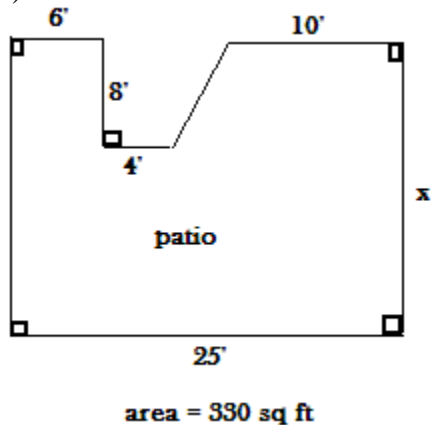

d)

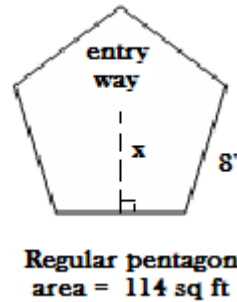

108. Aaron has volunteered to design a model of Loveland and the railroad as it looked 100 years ago. The model needs to fit on a piece of plywood that is 4 feet wide. The region that Aaron needs to show is about 600 feet wide. It is suggested that he choose a model train size from the scales in the table. Which scale best fits Aaron's model? Choose one.

Train Gauge (Scale)	Scale
Z	1:220
N	1:160
HO	1:87
S	1:64
O	1:48
MAXI	1:32
G	1:24

109. LHS real-estate company made the graph at right. It wanted to show that the company's annual income from rental properties doubled from 2005 to 2006.

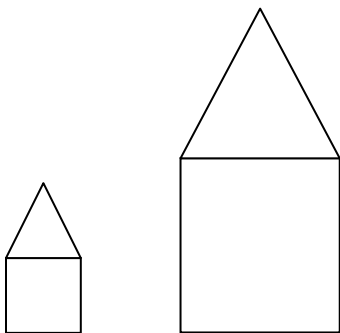

a) Find the area of each building at left. Use a ruler to find the dimensions in millimeters.

b) Why is the Rental Property Income graph misleading?

110. Loveland Builders are selling four **similar** building sites along the Poudre River. If the total river frontage of the lots is 400 feet, find the river frontage for each lot.

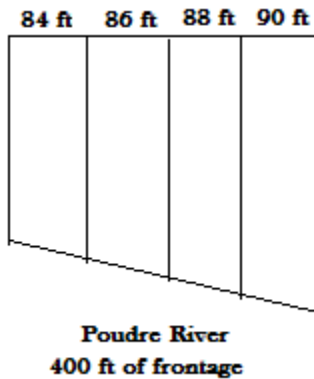

111. An example of a Geometry in Construction logo/sign is shown. The original toilet is outlined in copper pipe that is 15' long. The toilet seat is covered in 5 troy ounces of gold. The logo/sign is to be enlarged so that the 2 foot long tank becomes 7 feet long.

a) How much copper pipe is needed for the new logo?

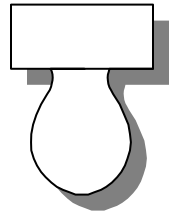

b) How much gold leaf will be needed to cover the new logo?

112. The ratio of sides of 2 similar polygonal shaped windows is 2:11

a) If the perimeter of the larger window is 80", what is the perimeter of the smaller window?

b) If the area of the smaller window is 44 sq inches, what is the area of the larger window? In square feet?

113. The ratio of the areas of 2 similar polygonal shaped gazebos is 16:121

a) What is the ratio of similarity (length ratio) for the two gazebos?

b) If the perimeter of the smaller gazebo is 112 feet, what is the perimeter of the larger gazebo?

114. The corresponding diagonals of two similar rectangular rooms are in the ratio of 1:5. What is the ratio of their areas?

115. The ratio of the areas of two similar rectangular baths is 1:16. What is the ratio of their lengths?

116. Find the area of the small figure given the area of the large is 72 square inches. The triangles are similar.

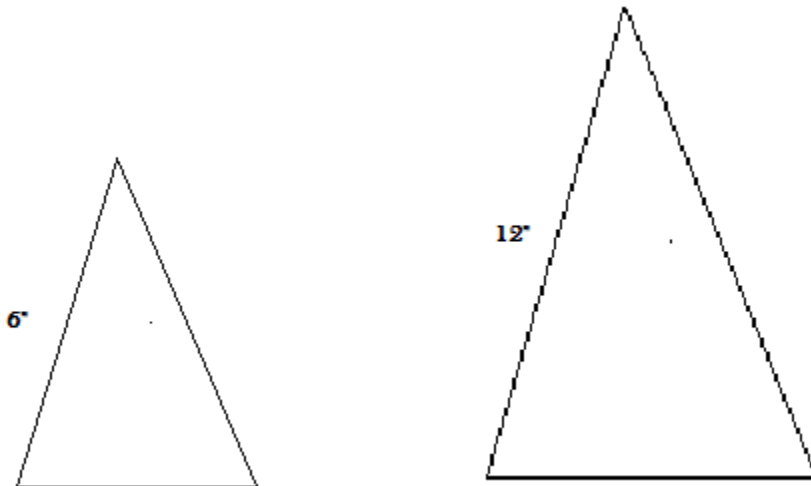

117. The two rectangles are similar. The ratio of their areas is 9:16. Find the missing side.

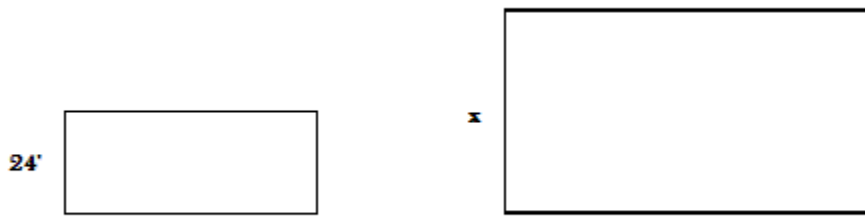

118. The two trapezoids are similar. Their area ratio is $16/25$. Find the missing length.

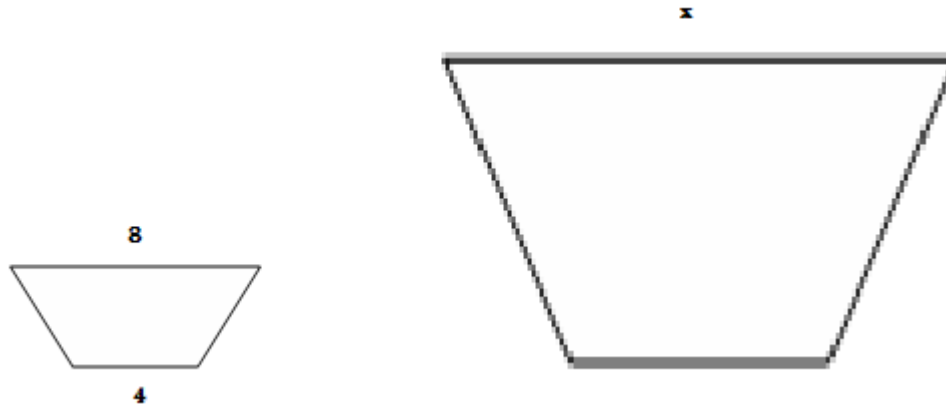

119. Find the area of the parallelogram.

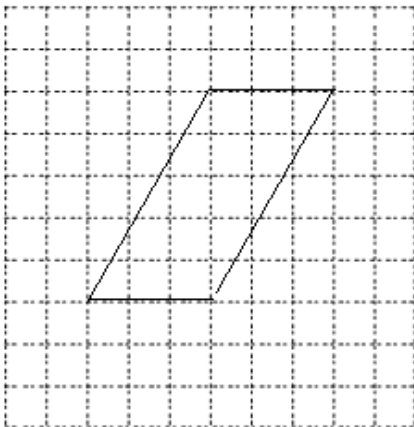

120. $\triangle ABC \sim \triangle ADE$ $AB = 4$ yards, $BC = 5$ yards, $AE = 21$ yards, and $DE = 16$ yards. Find BD

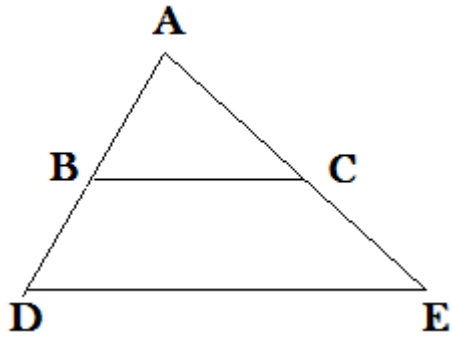

121. Find the surface area of the building (include the floor).

a)

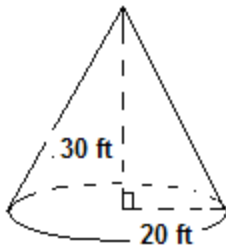

b)

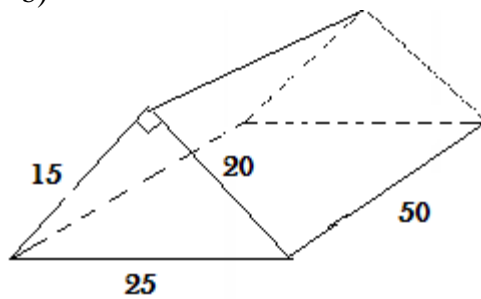

122. Felicia and Mindy are installing drywall in the ceiling of a house. The store told them that a full sheet of drywall weighs 100 lbs. If they can hold 60 lbs, can the ladies hang the two sheets shown below? What is the weight of each of the sheets? Note that all the sheets are drawn to scale. Show work

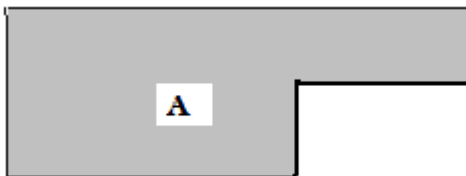
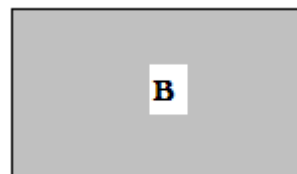
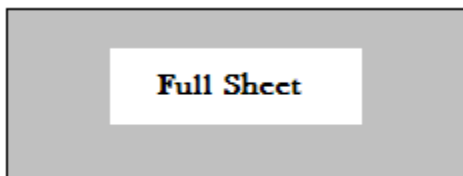

123. The 2 triangular lots, $\triangle ABC \sim \triangle DEC$ Find x

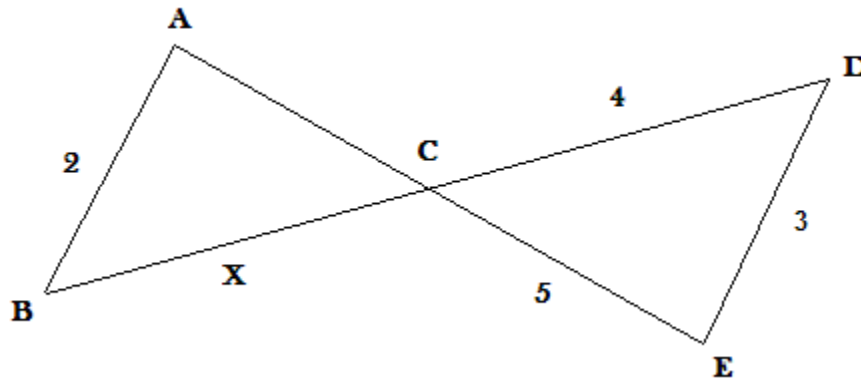

124. The circumference of a window in a bathroom is 8π . What is the area? Give answer in decimal and exact form.

125. Draw the image $\triangle ABC$ with a dilation of scale factor 3 and the image $\square DEFG$ with a dilation of scale factor $\frac{1}{2}$

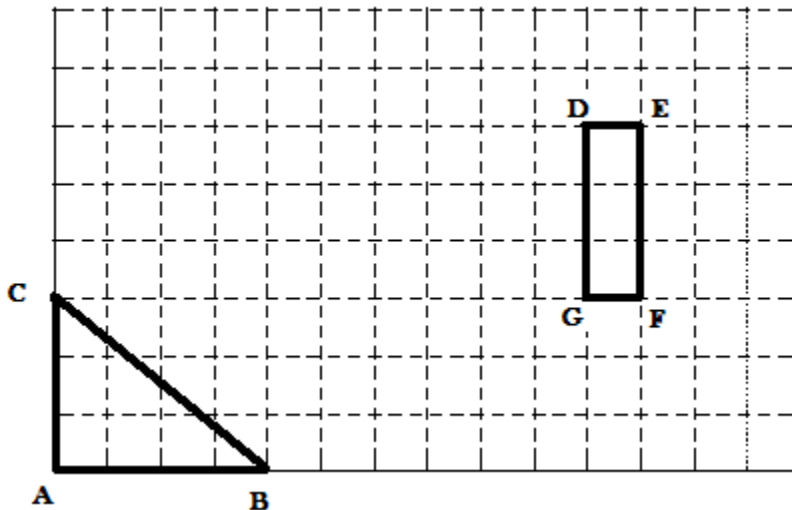

126. $\triangle ABC \sim \triangle DEF$ Find the value of x

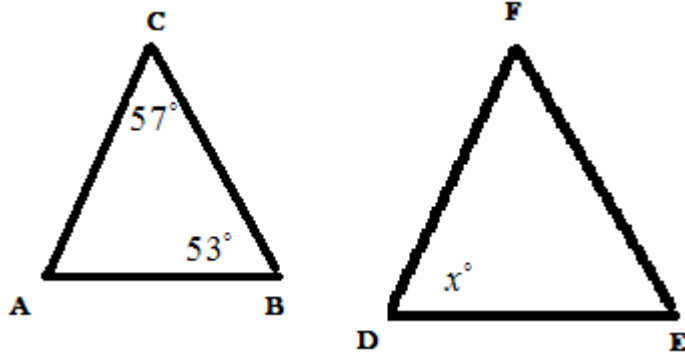

127. Mr. Burke has requested you to submit a floor plan of a room that is 18 ft by 18 ft. Your plan must be on an 8.5 in by 11 in paper. Choose the best scale to use?

$\frac{1}{2}$ in = 1 ft

$\frac{1}{4}$ in = 1 ft

$\frac{3}{8}$ in = 1 ft

128. Assume the figure area similar. The area of $\triangle ABC$ is 850 sq ft. Find the area of $\triangle DEF$

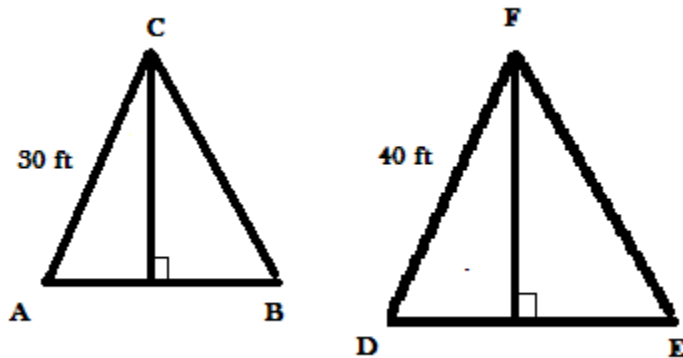

129. It cost \$1890 to carpet a living room. If the new design of the room is to cut the dimensions in half, what will it cost to carpet the new room?

130. Solve for x

a) $3x - 8 = 7x + 24$

b) $\frac{3}{7}x - 18 = -19$

c) $14 - 3x = 5(2x - 7)$

d) $9x - 5 = 9x$

e) $8(x - 1) = -8$

f) $60 + 6x = 2(3x + 5) - 5x$

131. A circular mounting plate is needed for an overhead light. The requirements are for the diameter to be 4 inches and the circumference is to be 8 inches. Can it be done?

132. Using a ruler, decide if the 2 gables (triangles) are similar. Please state why/why not the gables are similar.



Unit 1 Answers

1. 150 ft^2
2. $5\frac{13}{15} \rightarrow 6 \text{ rolls}$
3. $\approx 270 \text{ ft}^2 \rightarrow \945
4. $A \approx 6600 \text{ yd}^2 P \approx 370 \text{ yd}$
5. a) area
b) perimeter
c) perimeter
d) area
6. $\approx 1692 \text{ ft}^2$
7. a) $x = 5$
b) $x = \frac{10}{3}$
c) $x = \frac{1}{3}$
d) $x = -5$
e) $x = -9$
f) $x = -6$
8. 318150 ft^2
9. 2 gallons
10. 480 ft^2
11. 4 rolls
12. 457,700 sq ft
13. 800,000 cubic yards
14. \$910
15. $ac + ad$
16. 21,287.5 sq. ft.
17. 7 squares (672 sq ft)
18. 24 sq ft

19. a) 28 sq ft
 b) 717.5 sq ft
 c) 220.5 sq ft
 d) 450 sq ft
 e) 20.22 ft
 f) 18 ft
 g) $26\frac{2}{3}$ ft
 h) 247.8 sq in
 i) 398.75 sq ft
 j) 121π sq yd

20. a) $n = -3$
 b) $x = 9$
 c) $x = 50$
 d) $n = -2.8$
 e) $n = 3$
 f) $n = 4$

21. area: 9, 16; 45, 180; 40, 250

$$\text{Ratio of area } 6250\pi \quad \frac{9}{16} \quad \frac{1}{4} \quad \frac{4}{25}$$

$$\text{Ratio of sides} \quad \frac{3}{4} \quad \frac{1}{2} \quad \frac{2}{5}$$

a) Square of the side ratio is the area ratio

22. 8926.99 sq in

23. 512 tiles

24. 152 sq ft

25. 352 sq ft

26. \$3993.60

27. a) $4y - 2$
 b) $-3y^2 + 21y - 30$

28. a) $6x$
 b) $4x$
 c) $5x^2$

29. a) $\frac{7}{8}in = 250ft$ or $\frac{1}{8} = 35.7ft$
 b) 392.8 ft; 98,214.3 sq ft
 c) \$75,000; \$98,214.30
30. a) 6000 sq ft
 b) 696 sq ft
 c) 5304 sq ft
31. a) 472.89 sq ft
 b) 480 sq ft
32. A = 1080 sq ft, B = 315 sq ft, C = 567 sq ft, D = E = 416 sq ft; Total = 2794 sq ft
33. a) 1924 sq ft
 b) 2550 sq ft
34. 1082 sq ft
35. $8.8\bar{3}$
36. 29 sq yd
37. 30 sheets
38. 235.62 sq ft or 75π sq ft
39. a) $x = 67.5$
 b) $x = -7$
 c) $x = 11$
 d) $x = 78$
 e) $x = 0$
 f) $x = -12$
40. walls = 456,960 sq ft floor = 295,936 sq ft
41. 1340 sq ft
42. a) 94,317 sq ft
 b) 189 gallons
 c) 472 gallons
43. 4146.9 sq in

44. a) 2000 sq ft
b) 44.7 ft
c) square = 178.9 ft
45. a) 113.7 sq ft
b) 113.7 sq ft
c) 428 sq ft
d) 48π or 150.8 sq ft
46. a) 387 sq in
b) 1382.3 sq in
c) 1520.5 sq in
d) 414 sq in
e) 2627 sq ft
f) 1680 sq ft
47. 20π or 62.8 units
48. 30.8 units
49. 14π or 44 units
50. 18π or 56.5 units
51. \$800
52. 6.25 in; 8.33 in; 10 in
53. a) no solution
b) all real numbers
c) $x = 0$
54. 53a has no answers working where as 53b any answer works
55. 144π or 452.4 sq units
56. 625π or 1963.5 sq units
57. 64π or 201.1 sq units
58. 176.7 sq units
59. a) 353.4 sq ft
b) 530.1 sq ft

60. \$342
61. 1206 sq ft; 1507 sq ft; 1356 sq ft
62. a) 12566.4 sq ft c) 2063.5 sq ft e) 360 sq ft
 b) 6785.8 sq ft d) 1105.3 sq ft f) 380 sq ft
63. 5600 sq ft
64. 6 lots; varied answers could include access issues and are they buildable (realistic) lots.
65. $1''=4 \text{ ft}$ or $\frac{1}{4} \text{ in} = 1 \text{ ft}$
66. approximately 24.5 ft
67. a) $x = 15$
 b) all real numbers
 c) $x = -1$
 d) no solution
68. 14965.1 sq ft
69. 36 sq units
70. a) triples
 b) 9 times
71. 5 ft by 14 ft
72. $2\frac{1}{2} \text{ in}$ by $3\frac{1}{8} \text{ in}$
73. 112 sq ft
74. 400 ft
75. 60 sq in
76. 704 sq ft and 904 sq ft
77. $6.\bar{6} \text{ ft}$
- 78 a) $x = -2$ b) $x = -2$
 c) no solution d) all real numbers

79. a) 640 in
b) 7.36 in
80. even though the dimensions are doubled, the area is 4 times as much
81. 50 ft by 130 ft
82. 32 ft by 28 ft
83. 30 inches
84. 22.9 ft; because of similar triangles
85. varied
86. 13.5 ft
87. 10 ft
88. 7.5" by 9"
89. 100.8 inches or better answer is about $100\frac{13}{16}$ inches
90. For the ones on the right, the width of the small rectangle was doubled to get the width of the larger rectangle. However, the height was not. The sides are not in the same ratio.
91. a) $10x^2$
b) $7x$
c) $x = \frac{8}{9}$
d) $x = .5$
92. 60 inches by 102 inches
93. 33 ft
94. a) $\frac{920}{360} = \frac{23}{9}$
b) 4600 ft; 1800 ft
c) $\frac{4600}{1800} = \frac{23}{9}$
d) same
95. 19.8 ft

96. $x = 1$ ft
97. 22 yd
98. 12 in
99. 393.75 in
100. $33\frac{1}{3}$ inches
101. Varied
102. Carpet is the better buy at \$2.82 per sq ft.; Carpet costs \$639.40 while laminate costs \$794.12
103. \$1800
104. a) $x = 602$
b) $x = -4$
c) $x = 6$
105. 282.74 cm
106. a) 2629.51 sq ft
b) 540 sq ft
c) 10305.995 sq ft
d) 816.9 sq ft
107. a) 3.40 ft
b) 7.1 ft
c) 15.28 ft
d) 5.7 ft
108. N gauge
109. a) 150 sq mm and 600 sq mm
b) more than twice the area
110. 96.55 ft, 98.85 ft, 101.15 ft, and 103.45 ft...notice the pattern
111. a) 52.5 ft
b) 61.25 troy ounces
112. a) 14.55 in

b) 1331 sq in; 9.24 sq ft

113. a) $\frac{4}{11}$

b) 308 ft

114. $\frac{1}{25}$

115. $\frac{1}{4}$

116. 18 sq in

117. 32 ft

118. 10

119. 15 sq units

120. 8.8 yd

121. a) 3522.35 sq ft

b) 3300 sq unit

122. Sheet A weighs 79.8 lbs; No
Sheet B weighs 62.9 lbs; No

123. $2.\bar{6}$

124. 50.27 sq units; 16π sq units

125.

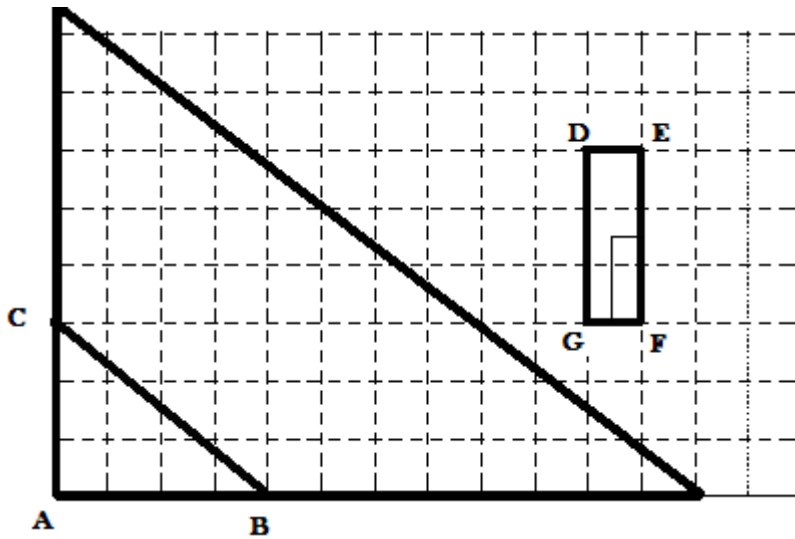

126. 70°

127. $\frac{3}{8} = 1ft$

128. $1511.\bar{1}$

129. \$472.50

130. a) $x = -8$

b) $x = \frac{-7}{3}$

c) $x = \frac{49}{13}$

d) no solution

e) $x = 0$

f) $x = -10$

131. Not possible

132. Yes, built to be....but the measures may not be proportional so therefore not similar